

Uniclass L21725	
CI/SIB (52.9)	

ACO Building Drainage

Drainage systems



Product catalogue

ACO Mobile Grease Management System



ACO Mobile - Effective Grease Management

FOR PUBS, CAFÉS, SNACK BARS, CAFETERIAS & TEA ROOMS

Operation Choice 1 - Gravity Separator Mode

- ▶ Simplest form of grease management system
- ▶ Separates fats, oils & grease by natural floatation
- ▶ Very reliable operation
- ▶ Highly tolerant of rapid wastewater temperature and flow rate fluctuation
- ▶ Free-standing, low footprint unit
- ▶ Supplied complete with 40mm and 50mm universal flexible waste pipe connectors for easy installation and removal
- ▶ Suitable for single sink or dishwasher operation
- ▶ Separator nominal size: NS 0.3. Maximum flow rate: 0.3 litres/sec
- ▶ Manual grease/sludge removal. Grease skimmed off into airtight container for 'bag it and bin it' disposal
- ▶ Optional stainless steel sediment basket to collect food solid residues

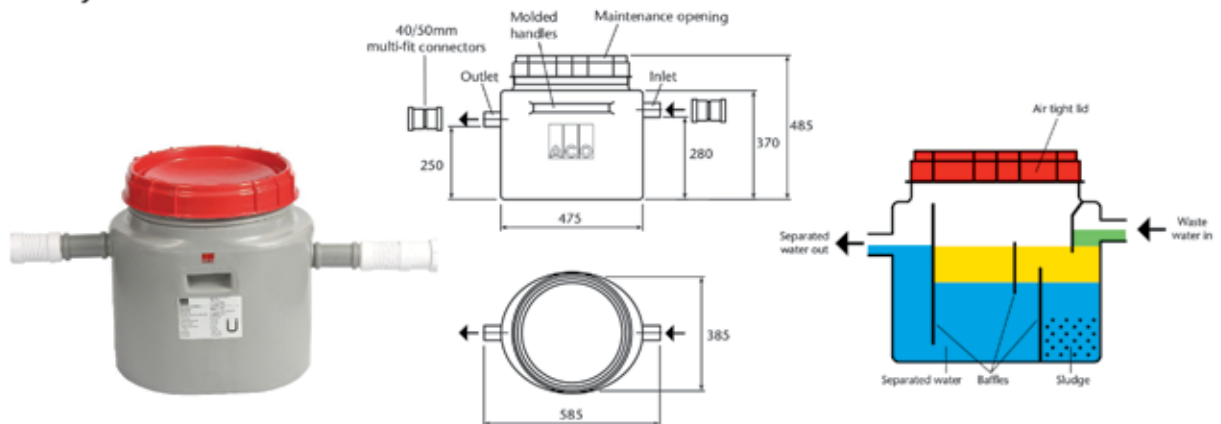

Description	Part No	Capacity (litres)		Total	Weight (kg)	
		Grease Storage	Sludge Trap		Empty	Filled
ACO Mobile Grease Separator	105460	9	10	32	11	42

Accessories - (Gravity separator mode)

- ▶ 304 grade stainless steel perforated sediment basket (6mm perforations)
- ▶ Manually operated isolation valve kit (2 valves supplied) for sealing trap inlet and outlet for removal for hygienic servicing away from kitchen environment



Stainless Steel Sediment Basket

Description	Part No	Weight (kg)
Sediment basket	105457	2



50mm Isolation Valve Kit (inlet & outlet)

Description	Part No	Weight (kg)
Isolation valve kit	105459	1

ACO Mobile - Effective Grease Management

FOR PUBS, CAFÉS, SNACK BARS, CAFETERIAS & TEA ROOMS

Operation Choice 2 - Enzyme Activator Mode Starter Package

- ▶ Packaged grease trap starter system complete with grease trap, 5 litres ACO Clear enzyme activator, programmable automatic dosing pump, waste fitting kit, 40/50mm universal flexible waste pipe connectors for easy installation and removal
- ▶ Degrades fats, oils and grease using natural processes
- ▶ Free-standing, low footprint unit
- ▶ 230V programmable dosing pump minimises human error with timer memory in event of power failure
- ▶ Suitable for single sink or dishwasher operation
- ▶ Maximum flow rate: 0.3 litres/sec
- ▶ Optional stainless steel sediment basket to collect food solid residues

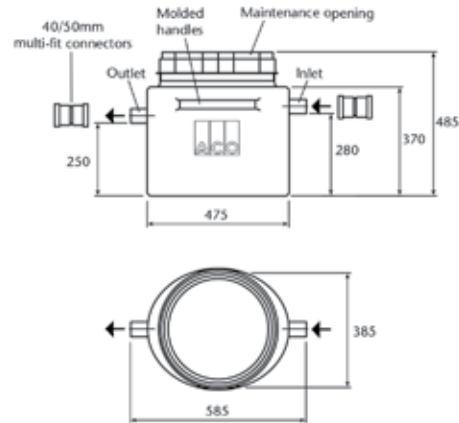

Description	Part No	Capacity (litres)		Weight (kg)	
		Sludge Trap	Total	Empty (Total System)	Filled
ACO Mobile Enzyme Grease Trap System	105461	10	32	19	42

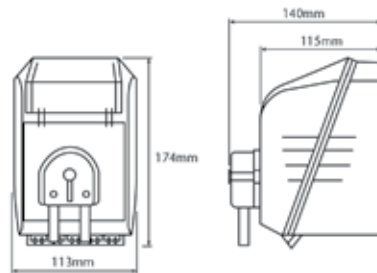

Programmable Automatic Enzyme Dosing Unit



Waste Fitting Kit

Accessories - (Enzyme activator mode)

Description	Part No	Weight (kg)
Stainless steel perforated sediment basket (see Page 2 for detail)	105457	2
Manually operated isolation valve kit (see Page 2 for detail)	105459	1
5 litres ACO Clear enzyme activator	49020	5
20 litres ACO Clear enzyme activator	49022	20



Your local sales contact

ACO Systems SA
Route 21 Corporate Business Park
Dunham Bush House
57 Sovereign Drive
Irene Ext 30
South Africa
0157

Tel. +27 12 941 0521
Fax. +27 86 5489 318
info@aco.co.za
www.aco.co.za